

# Contenitore in Polipropilene Multi-Cartuccia 5x30"

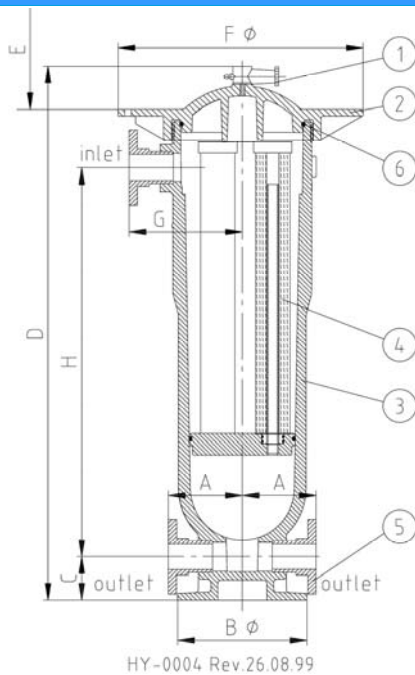

1. Vent valve
2. Lid
3. Housing body
4. Cartridge
5. Flange adapter 2"
6. Lid gasket



HY-0004 Rev.26.08.99

size	A	B	C	D	E	F	G	H
530	145	254	83	1221	914	467	219	933

all dimensions in mm

Specification (changes possible w/o notice)

For filter cartridges  
 No. of cartridges  
 Cartridge length  
 Max. recommended flow rate (m<sup>3</sup>/h)  
 Filter area (m<sup>2</sup>)  
 Filter housing volume (litre)  
 Filter housing weight (kg)  
 Mode of installation  
 Material of construction  
 Operating data  
 Housing connections  
 Parking

Housing  
 Restrainer basket  
 Lid (closure)  
 N1/N2 (inlet/outlet)  
 N3 (lid hole)  
 Corrugated box (cm)

CT5P3-2" ANSI Flg

DOE (edge knife sealig) or SOE (222-Oring)  
 5 x 30"  
 30"15  
 dep. on type of filter cartridge  
 36  
 approx. 30  
 approx. 91  
 approx. 60 x 60  
 Integrally moulded mounting flange  
 Polypropylene glass-reinforced  
 Polypropylene glass-reinforced  
 Polypropylene glass-reinforced  
 max. 10.3 bar / 21°C non shock  
 2" ansi flange (two separate screw in flanges)  
 5/8" NPT with vent valve  
 L = 123 x W = 52 x H = 52

147\_00\_EN



UK Office:

Envirogen Group  
 Unit 14a Bromyard Road  
 Trading Estate  
 Bromyard Road, Ledbury  
 Herefordshire HR8 1NS  
 Tel: +44 (0) 1531 636328  
 E: info@envirogen.com  
 www.envirogen.com



Italian Office:

Envirogen Group Italy S.p.A  
 Viale De GASPERI,88/B  
 20017 Mazzo di Rho Milano  
 Tel: +39 (0)2 93959.1  
 E: info.it@envirogen.com  
 www.envirogen.com



USA Office:

Envirogen Technologies  
 Two Kingwood Place  
 700 Rockmad Dr. Suite 105  
 Kingwood, TX 7739  
 Tel: +1 877.312.8950  
 E: info@envirogen.com  
 www.envirogen.com